



## Performance you can depend on

INFICON offers the world's leading technology in the field of measuring technology, sensor technology and process control for sophisticated vacuum processes in highly specialized industries. INFICON products for gas leak detection are used, in particular, in the refrigeration and air conditioning sectors, in semiconductor manufacturing and in automobile production.

With INFICON, you have a competent service representative at your side who knows the challenges of your industry and who, together with you, will find the optimal solution for your requirements. INFICON ensures the best service and the greatest possible support for your company through our specialized experts in numerous branch offices worldwide. INFICON's state-of-the-art production facilities are located in the USA, Europe and Asia.

### TECHNICAL SPECIFICATIONS

Minimum detectable leakage rate of helium:	
"Ultra" mode	$\leq 1 \cdot 10^{-11}$ mbar l/s (> 5 l/s helium pumping speed)
"Fine" mode	$\leq 5 \cdot 10^{-11}$ mbar l/s (1.7 l/s helium pumping speed)
"Gross" mode	$\leq 1 \cdot 10^{-9}$ mbar l/s
"Sniffer" mode	$\leq 1 \cdot 10^{-7}$ mbar l/s
Units of measurement (options)	mbar l/s, Pa m <sup>3</sup> /s, atm cc/s, g/a, ppm
Maximum permissible inlet pressure:	
"Gross" mode	18 mbar
"Fine" mode	0.9 mbar
"Ultra" mode	0.2 mbar
Response time	< 1 s
Ion source	2 yttrium/iridium long-life cathodes (3 year warranty)
Digital inputs/outputs	10 inputs, 8 outputs (when used with I/O1000 module)
Control input	PLC compatible (max. 35 V)
Lin/log recorder output	0 - 10 V
Serial interface	RS232, RS485 or fieldbus systems
Dimensions (L x W x H)	330 x 240 x 280 mm
Ambient temperature (operation)	10 - 45°C
Warranty	2 years (3 years on ion source)

### ORDERING INFORMATION

#### BASE UNITS

PRODUCT	CAT. NO.	PRODUCT	CAT. NO.
LDS3000, base unit	560-300	Pump module	14511
I/O1000 module (input/output module)	560-310	(complete, incl. connection accessories)	
BM1000 bus module		TRIVAC D 4 B,	
Profibus	560-315	1-phase motor 230 V, 50/60 Hz	
Profinet	560-316	Sniffer valve	14520
DeviceNet	560-317	Sniffer line, incl. handpiece,	
EtherNet/IP	560-318	with 200 mm sniffer tip	
Data cable (MSB/I/O1000/BM1000)		3 m line length	14521
2 m cable length	560-332	5 m line length	14522
5 m cable length	560-335	10 m line length	14523
10 m cable length	560-340	XL Sniffer Adapter	560-319
An I/O1000 module or BM1000 module as well as a data cable are necessary for the operation of an LDS3000.		Diaphragm pump	560-330
The data cables can be used for connecting to an I/O1000 module or a BM1000 bus module and the CU1000 control unit.		(recommended to use with the XL Sniffer Adapter)	
<b>OPTIONS</b>		External test leak with 100% H <sub>2</sub> (leak rate of test leak corresponds to (95/5) forming gas leak rate)	12322
CU1000 control unit	560-320	External helium test leak	12237
Snap-on mounting rail power supply unit 24 V, 10 A	560-324	Sniffer lines to use in combination with the XL Sniffer Adapter	
Internal test leak TL7	560-323	SL3000XL-3, 3 m line length	521-011
		SL3000XL-5, 5 m line length	521-012
		SL3000XL-10, 10 m line length	521-013
		SL3000XL-15, 15 m line length	521-014



## LDS3000 helium and hydrogen leak detector

The centerpiece of automated leak testing systems



[www.inficon.com](http://www.inficon.com) [reachus@inficon.com](mailto:reachus@inficon.com)

Due to ongoing product improvements, specifications may change without prior notice.  
kiba40de1-04-(2003) © 2020 INFICON





# Compact performance at the highest level

The LDS3000 is the centerpiece of automated leak testing systems. The successor to the LDS2010 sets new standards in terms of accuracy, reproducibility of measurement results and leak detection speed. The LDS3000 is extremely compact. Its small size (330 x 240 x 280 mm) means that the unit can now be flexibly integrated into leak testing systems much more easily. And that's not all, because the lack of a 19" control module and significantly optimized cabling have further reduced the space needed and made installation even easier. An optional touchscreen control is also available and it is possible to connect fieldbus systems.

## MORE COMPACT AND EASIER TO INTEGRATE

The art of plant engineering is all about optimizing space requirements and ease of installation. The response of the LDS3000 to these challenges for leak testing systems comes in the form of its small size, compact design and optimized cabling. Not only is it more powerful than its predecessor, the LDS2010, it also has such a compact design that it can be integrated into leak testing systems more easily and flexibly. The unit is also complemented by individual, customized operating systems such as touchscreen operation or connection to fieldbus systems, which are available as an

option. In combination with the XL Sniffer Adapter, the LDS3000 becomes a powerful sniffer leak detector for helium and hydrogen, which is able to localize leaks both at low flow rates (300 sccm) and at high flow rates (3000 sccm).

## VERSATILE COMMUNICATION

As far as its communication interfaces are concerned, the new LDS3000 leaves no stone unturned. Alongside a wide range of analog interfaces, the LDS3000 also offers numerous digital interfaces. RS232, RS485, USB and Profibus (optional) give the user more possibilities to use the LDS3000 according to their needs.

## DIMENSIONAL DRAWING

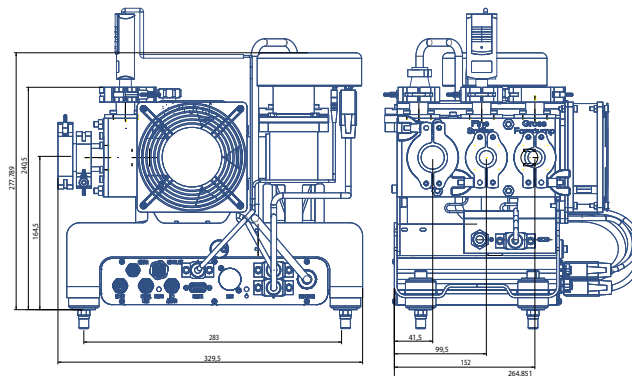

## YOUR BENEFITS AT A GLANCE

- Compact design allows individual, customized integration into leak testing systems
- Versatile communication through numerous analog and digital interfaces
- Significantly optimized cabling increases usage flexibility, even lengths of up to 30 m are possible
- Fast and easy updates are possible through USB port

- Fast and optimized response times due to I-CAL
- LDS2010 compatibility mode
- XL Sniffer Adapter converts the LDS3000 into a sniffer leak detector
- cTÜVus – Certified according to Canadian and US standards (NRTL approved)



CU1000 CONTROL UNIT



BM1000 BUS MODULE



I/O1000 MODULE



CALIBRATED STANDARD TEST LEAK TL7 AND SNIFFER LINE UP TO 10 M

## HIGHLY RELIABLE

The LDS3000 combines high throughput rates with both quality and reliability. Downtime and frequent maintenance have been consigned to the past. With times of just 20 seconds, calibrations are particularly quick and rarely have to be performed. Leak rates of up to  $1 \times 10^{-11}$  mbar l/s are confirmed in significantly less than 1 second.

## ADVANTAGES DURING USE



cTÜVus CERTIFIED  
(NRTL APPROVED)



## Calibration

New, patented routine allows calibration of the LDS3000 within 20 seconds.

## Implementation of I-CAL

I-CAL is the effective algorithm for quick, reliable detection of the smallest leaks in the sensitive measurement range. Cycle times are decreased as a result and greater sensitivity is achieved. I-CAL has been successfully used with INFICON products for several years.

## TMP compression

The high helium pumping speed and high compression of the powerful turbo molecular pump make leak detection applications resistant to downtimes caused by helium contamination. The pump allows inlet pressures up to 18 mbar for applications with minimal detection limit requirements.



DATA CABLE



CU1000 OPTIONAL TOUCHSCREEN DISPLAY